



INSTRUCTIONS

FOR

AC BRIDGE

BR - 8

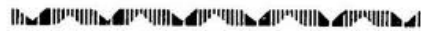

SPECIFICATIONS

☆ Ranges:

R: $0.1\Omega \sim 11.1M\Omega$

Accuracy: $0.1\Omega \sim 10\Omega$: $\pm 2\% + 0.1\Omega$

$10\Omega \sim 5M\Omega$: $\pm 1\%$

$5M\Omega \sim 11.1M\Omega$: $\pm 5\%$

L: $1\mu H \sim 111H$

Accuracy: $1\mu H \sim 100\mu H$: $\pm 5\% \pm 1\mu H$

$1mH \sim 111H$: $\pm 2\%$

C: $10pF \sim 1110\mu F$

Accuracy: $10pF \sim 1000pF$: $\pm 2\% \pm 10pF$

$1000pF \sim 111\mu F$: $\pm 1\% \sim 1.5\%$

$111\mu F \sim 1110\mu F$: $\pm 5\%$

T: $1/10000 \sim 1:11100$

Accuracy: $\pm 1\% \sim 1.5\%$

☆ Power Source: DC 9V(006P X 1)

☆ Bridge Power Source: 1KHz

☆ Net Weight: 1Kg

☆ Dimensions: 128mm X 182mm X 75mm

- *Left dial indicates "1" at the lowest position.
- *Center dial indicates "2" at the lowest position.
- *Right dial indicates "5" at the lowest position.

Note: When the range selector is set to "100 ohms—111 K. ohms" position, if the three dials indicate the following numbers at the lowest positions:

Left dial	10
Center dial	5
Right dial	7

the value of a resistor is 105.7 K. ohms.

9. When the value of a resistor to be measured is unknown, set the three dials to "5" position respectively and set the meter pointer by "SENS" knob to the center of the scales. Then seek the proper range by turning the range selector, which is at the lowest position that the meter pointer indicates.

Note: "LOSS BAL" knob must be set to "0" at any time.

CAPACITANCE (C):

1. Set the selector switch to "C" position.
2. Set "LOSS BAL" knob to "0" position. But, if the pointer swing is weak in measuring a electrolytic condenser, the pointer must be adjusted by "LOSS BAL" knob for an accurate reading.
3. Connect a capacitor to be measured to "X" terminals.

- Measurement can be done by the same procedures as resistors.

INDUCTANCE (L):

- Set the selector switch to "L" position.
- Set the range selector to the proper position.
- Connect a coil to be measured to "X" terminals.
- Set "LOSS BAL" knob to "0.4- 0.8" position.
- Set the meter pointer to the center of the scales.
- Set the left dial to each position from 0 to 10, and turn "LOSS BAL" knob for each position so that the meter pointer may indicate the lowest position. Compare these lowest positions and read the dial at the most lowest position. Continue the same procedures on the center and right dials, too.

For example, a coil of 1.77mH can be measured as follows:

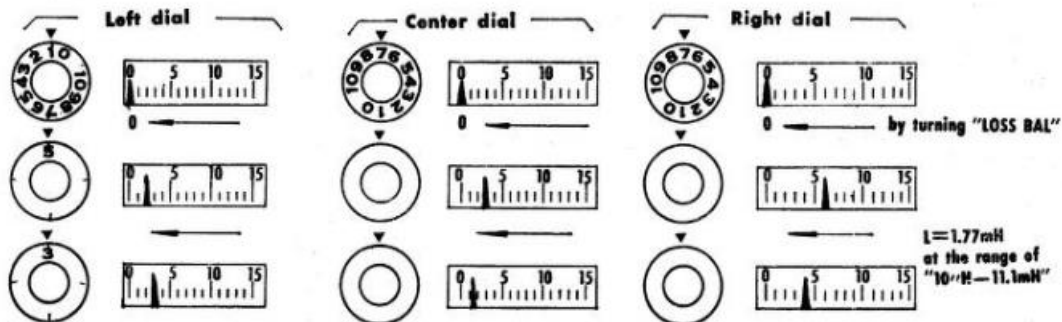

Note: When the meter pointer indicates "0" on two or three positions of the dial by turning "LOSS BAL" knob, turn "SENS" knob slightly to the right and continue the measurement.

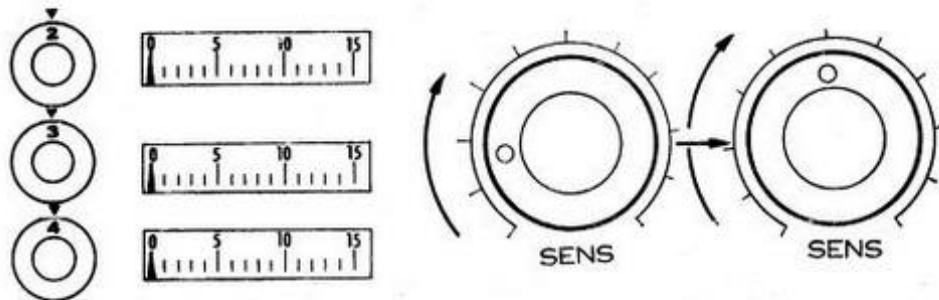

When measuring an unknown inductance, seek the proper range by turning the dials and "LOSS BAL" knob.

TURN RATIO (T):

1. Set the selector switch to "T" position.
2. Set the range switch to the proper position.
3. Set "LOSS BAL" to "0" position.
4. Connect the primary and secondary lead wire of a transformer to be measured to "RED" terminal. Connect the another primay lead wire to "N1" terminal and the another secondary lead wire to "N2" terminal.
5. Measurement can be done by the same procedures as resistors.

Note: In turning numbers, smaller one must be connected to "N1" terminal and larger one must be connected to "N2" terminal. In ratio of N1 to N2, "N1" should be "1" at any time. When "DIP POINT" cannot be obtained by adjusting dials and "SENS" knob, connect the lead wires conversely.

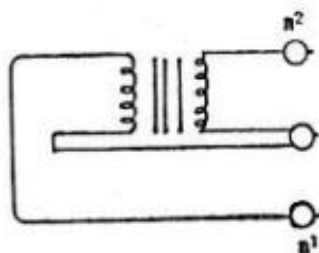

MODEL BR-8 SCHEMATIC DIAGRAM

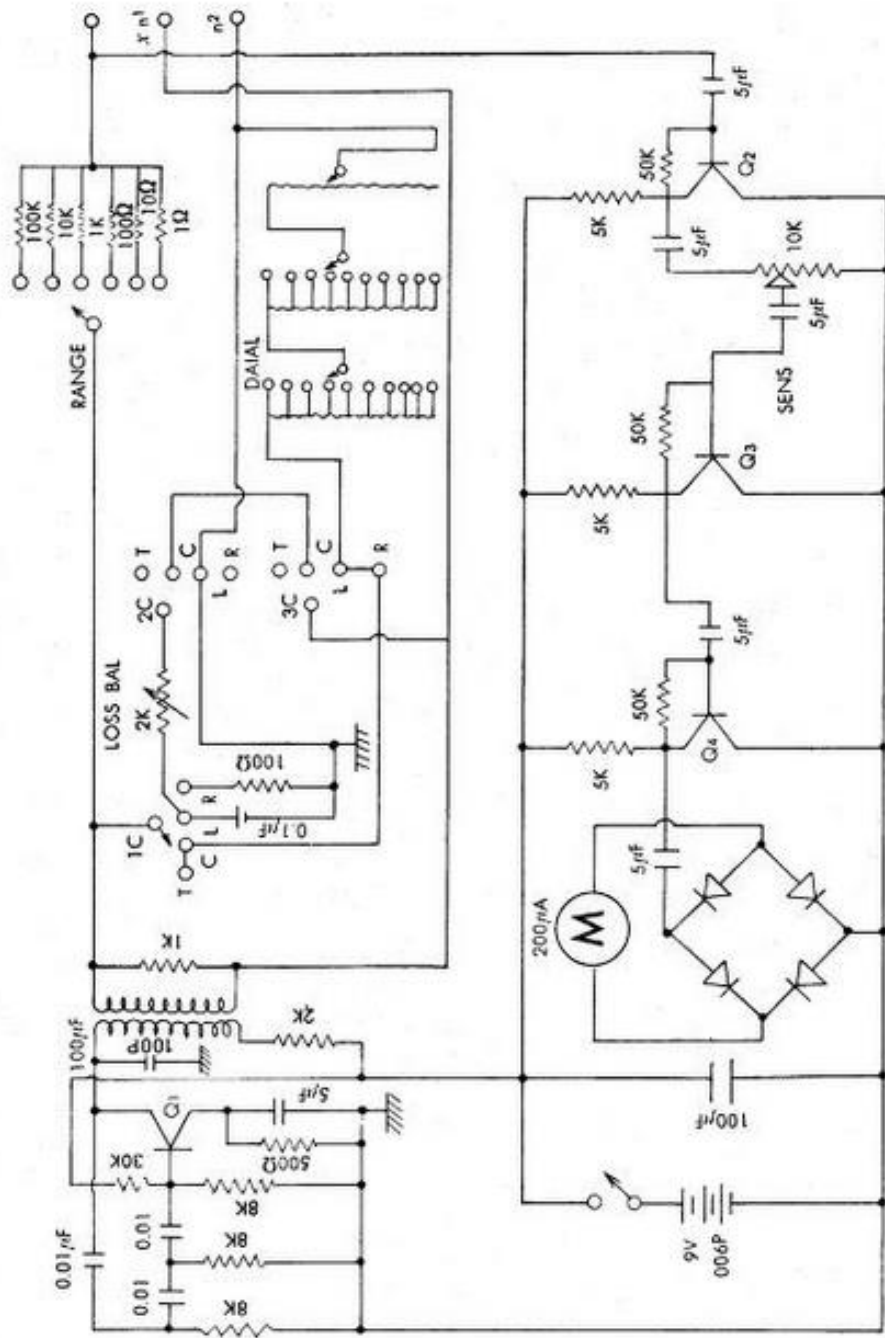

BELCO ELECTRIC CO., LTD.

TOKYO · JAPAN

Printed in Japan